

Electromagnetic Brake Motor

40 Watt

Frame Size: 90 mm

Continuous Rating with Frequent Start Stop,
Load Holding & Minimum Overrun.
Electromagnetic Fail Safe Brake (Power Off
Activated) fitted at the back.
Rotates in Clockwise or Counter Clockwise Direction.
Terminal box or Lead Wires for Connection.



Specifications:

Model	Supply Voltage	Frequency Hz	Current A	Starting Torque N.m	Rated Torque N.m	Rated Speed RPM	Capacitor μ F
90 EW 4□ 40	Single Phase 110V	50	0.70	0.20	0.30	1350	7.5
90 EX 4□ 40	Single Phase 230V	50	0.33	0.20	0.30	1350	1.85
90 EY 4□ 40	Three Phase 230V	50	0.33	0.40	0.30	1350	—
90 EY 4□ 40	Three Phase 415V	50	0.21	0.40	0.30	1350	—

Type Of Shaft, G for Gear Shaft, R for Round Shaft

Gearmotor Torque Table:

The maximum permissible torque is 20 N.m

50 Hz

Unit : N.m

RPM	500	416	300	250	200	166	120	100	83	60	50	41	30	25	20	16	15	12.5	10	8.3
Gear Ratio	3	3.6	5	6	7.5	9	12.5	15	18	25	30	36	50	60	75	90	100	120	150	180
Output Torque	0.72	0.87	1.2	1.5	1.8	2.2	3.0	3.6	4.4	5.5	6.6	7.9	9.9	11.8	14.5	17.7	19.5	20.0	20.0	20.0

The Gear boxes are sold separately.

A coloured background indicates gear shaft rotation in same direction as motor shaft.

A white background indicates gear shaft rotation in opposite direction to the motor shaft.

The speed of geared motor is calculated by dividing motor's synchronous speed by the gear ratio.

The actual speed is 2 - 20% less than the displayed value, depending upon the load.

Characteristics, specifications and dimensions are subject to change without notice.

Dimensions

Motor, Gearbox with Terminal Box

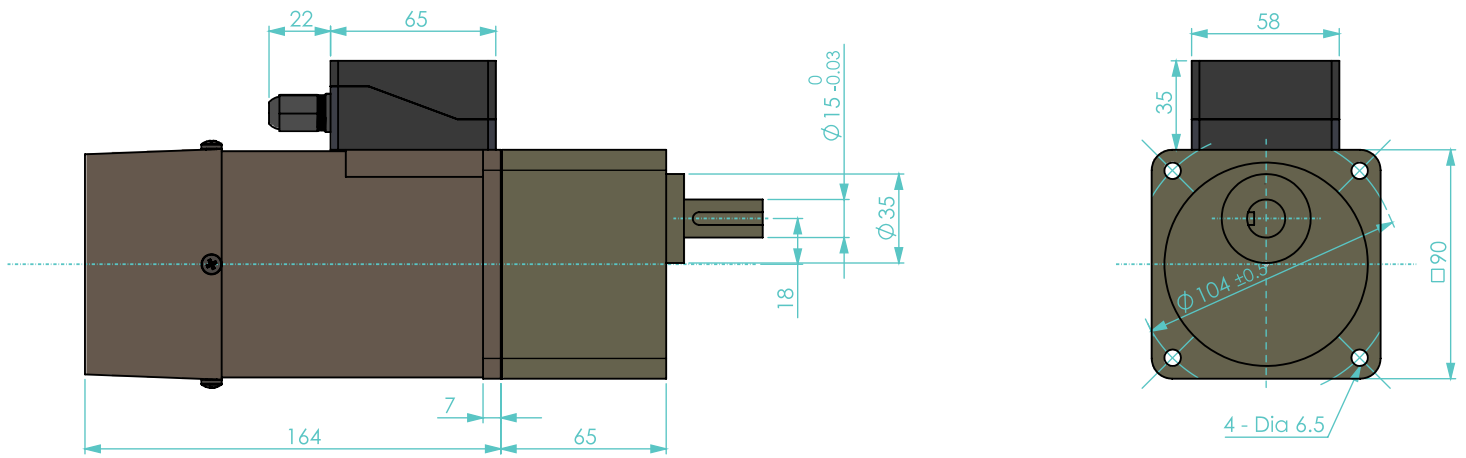

Motor Round Shaft with Terminal Box

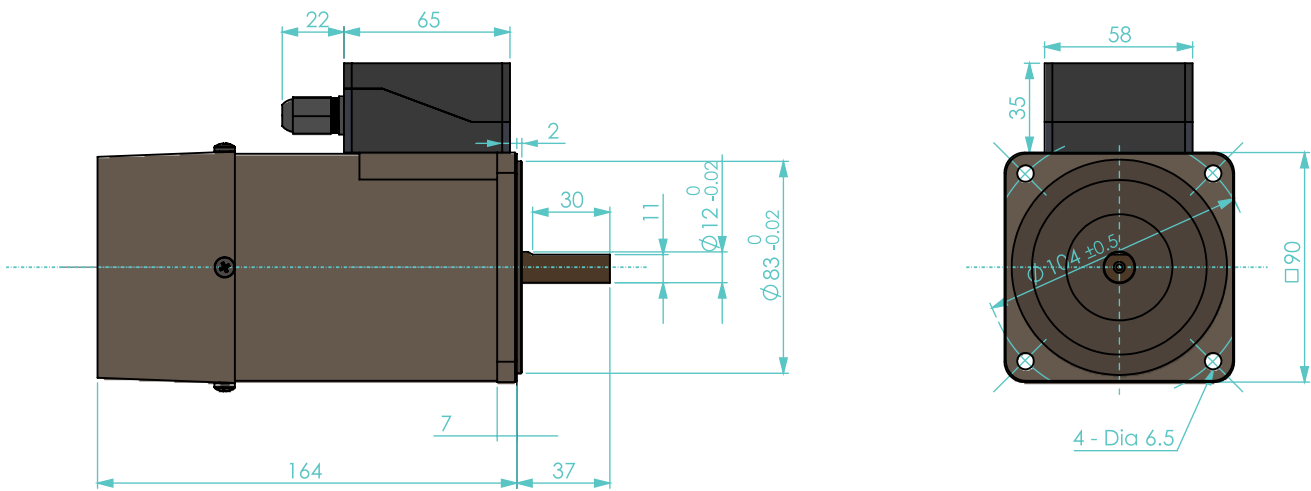

Motor, Gearbox with Lead wires

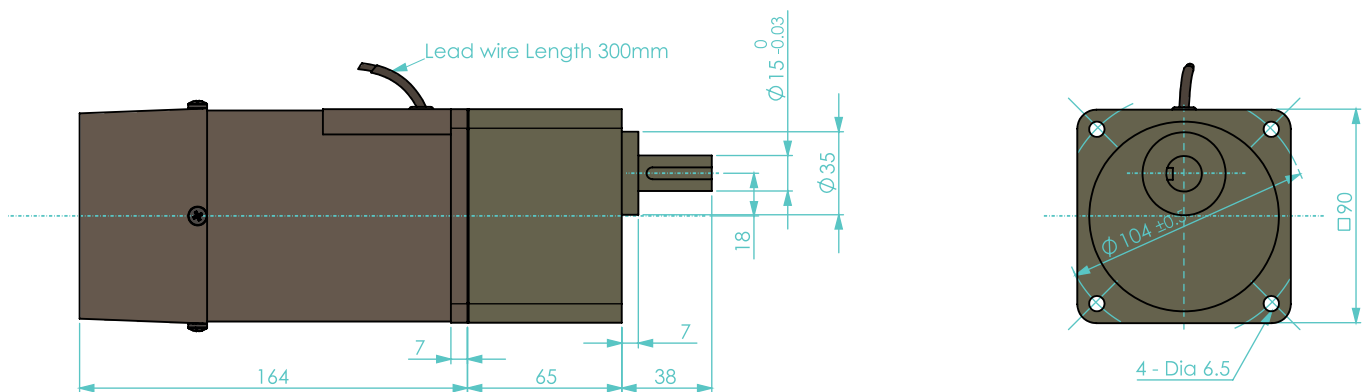

Key & Keyway

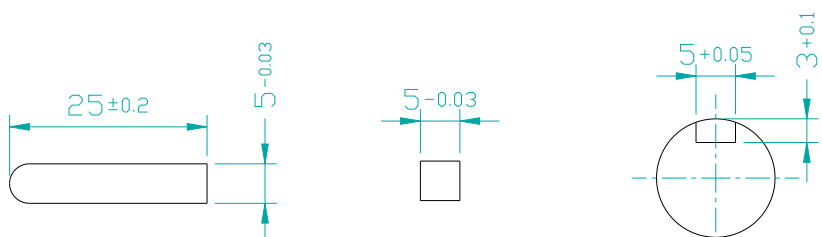

Electromagnetic Brake Motor

Wiring Diagram

Wiring Diagram for Single Phase Motor

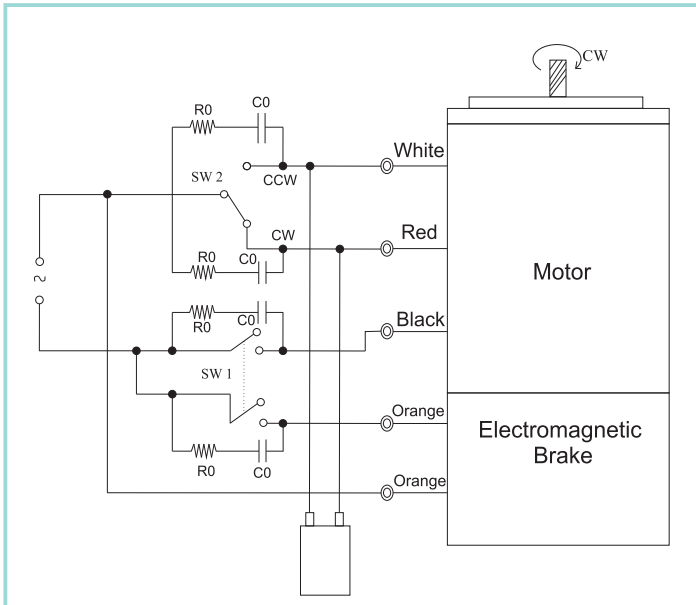

When SW1 is switched ON, Electromagnetic Brake is released & motor starts rotating. When SW1 is switched OFF then electro-magnetic brake will be applied stopping the motor immediately & holding the load.

Apply voltage on the orange brake lead wires only, to release the Electromagnetic Brake.

To change the direction of rotation, flip CW to CCW.

Wiring Diagram for Three Phase Motor

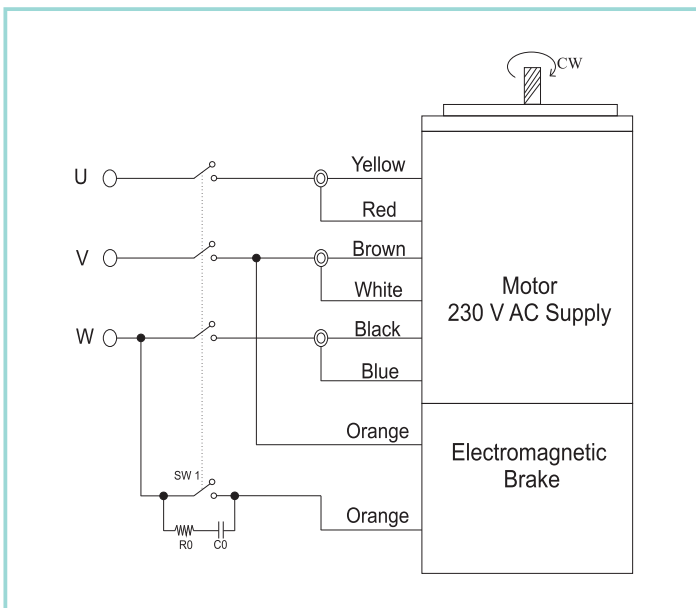

When SW1 is switched ON, electromagnetic Brake is released & motor starts rotating. When Sw1 is switched OFF then electro-magnetic brake will be applied stopping motor immediately, holding the load.

Apply voltage on the orange brake lead wires only, to release the Electromagnetic Brake.

To change the direction of rotation, interchange any two wires between U, V & W.